

SUPPLEMENTAL BID BULLETIN NO. 1

TITLE : Repairs and Improvements of Various Facilities at DSWD Central Office

ITB NO. : GOP/21-DSWD-023

DATE : 8 October 2021

This Supplemental/Bid Bulletin is issued to all prospective bidders announcing amendments/changes in the Bidding Documents, as follows:

I. Amendments/Changes in the Bidding Documents

A. Pre-Bid Conference

In view of absence of quorum of the Bids and Awards Committee (BAC) the following are the changes in schedule:

From	To
11 October 2021, 10:00 am	13 October 2021, 11:30 am

B. Section VI. Specifications under Contractor's Terms of Reference

Particular	From	To
Contractor's Responsibilities and Conditions for Lot No. 3	Xxx; C. Contractor is shall provide of operating Maintenance Manual for the newly improved water system.	C. Contractor shall provide operating Maintenance Manual for the newly improved water system <u>and shall be withheld an amount of Ten Thousand Pesos (PhP10,000.00) for failure on the submission of Manual within thirty (30) calendar days upon issue of certificate of completion</u>

Recommended Terms of Payment for Lot No. 1 to 3

From:

Payment Tranches	Outputs/ Deliverables
1st Tranche Fifteen Percent (15%) payment of the total contract cost (Mobilization fee based on the RA 9184)	Upon signing on Contract of Agreements and submission of provisions under item numbers C-5, C-8 & C-9.
2nd Tranche Fifty Percent (50%) payment of the total contract cost (Subjected for Deduction for 10% Retention & 15% Mobilization Fee)	Must be Fifty Percent (50 %) of project completion/ physical accomplishment with the submission of Billing Statement, Progress/Accomplishment Report, Statement of Work Accomplished, Progress Photos, and Narrative Report.
3rd Tranche Thirty Percent (30%) payment of the contract price (Subjected for Deduction for 10% Retention)	Must be Ninety Percent (90 %) of project completion/ physical accomplishment with the submission of Billing Statement, Progress/Accomplishment Report, Statement of Work Accomplished, Progress Photos, and Narrative Report.
4th Tranche (Final Progress Billing) Twenty Percent (20%) payment of the contract price (Subjected for Deduction for 10% Retention)	Must be Hundred Percent (100%) physical completed Upon with submission of Billing Statement, Contractors accomplishment reports, Statement of Work Accomplished, Progress Photos, Narrative report, Contractors certificate of completion, contractors request for acceptance and turn-over certificate.
5th Final Tranche Ten Percent (10%) payment of the total contract price (10% Retention Money)	Must be two (2) months and without damage/defect of installed items and Upon Submission of Contractors warranty security issued by the private insurance company, Notarized Certificate of Warranty, Signed & Approved Punch list report.

To:

Payment Tranches	Outputs/ Deliverables
1st Tranche Fifteen Percent (15%) payment of the total contract cost (Mobilization fee based on the RA 9184)	Upon signing on Contract of Agreements and submission of provisions under item numbers C-5, C-8 and C-9.

Payment Tranches	Outputs/ Deliverables
2nd Tranche Thirty Percent (30%) payment of the total contract cost (Subjected for Deduction for 10% Retention & 15% Mobilization Fee)	Must be Thirty Percent (30%) of project completion/ physical accomplishment with the submission of Billing Statement, Progress/Accomplishment Report, Statement of Work Accomplished, Progress Photos, and Narrative Report.
3rd Tranche Twenty Percent (20%) payment of the contract price (Subjected for Deduction for 10% Retention)	Must be Fifty Percent (50%) of project completion/ physical accomplishment with the submission of Billing Statement, Progress/ Accomplishment Report, Statement of Work Accomplished, Progress Photos, and Narrative Report.
4th Tranche Thirty Percent (30%) payment of the contract price (Subjected for Deduction for 10% Retention)	Must be Eighty Percent (80%) of project completion/ physical accomplishment with the submission of Billing Statement, Progress/ Accomplishment Report, Statement of Work Accomplished, Progress Photos, and Narrative Report.
5th Tranche (Final Progress Billing) Twenty Percent (20%) payment of the contract price (Subjected for Deduction for 10% Retention)	Must be One Hundred Percent (100%) physically completed with submission of Billing Statement, Contractor's accomplishment reports, Statement of Work Accomplished, Progress Photos, Narrative report, Contractor's certificate of completion, contractor's request for acceptance and turn-over certificate, Initial Acceptance issued by the DSWD

II. Section VII. Drawings

Please see attached drawings marked as:

- Annex A – Drawings for Lot 1
- Annex B – Drawings for Lot 2
- Annex C – Drawings for Lot 3

III. Deadline for the Submission and Receipt of Bids

The deadline for the submission and receipt of bids is on **25 October 2021, 09:00 a.m.** Bids must be delivered to the **BAC Secretariat Office, 2nd Floor Mahusay Building, DSWD Central Office.** Late Bids will not be accepted.

The Opening of Bids is on **25 October 2021, 10:30 a.m.** to be held at the **Procurement Management Service, BAC Secretariat Office, 2nd Floor, Mahusay Building, DSWD Central Office, IBP Road, Constitution Hills, Quezon City**

IV. Issuance of Bidding Documents

The issuance of bidding documents is until **09:00 a.m. of 25 October 2021.**

This Bid Bulletin shall form part of the bidding documents.

Please be guided accordingly.

RENE GLEN O. PAJE
*Undersecretary and
Bids and Awards Committee Chairperson*

Please accomplish the portion below and send it to facsimile no. (02) 951-7116 or email at bacsec@dswd.gov.ph.

Received from DSWD, **Supplemental/Bid Bulletin No. 1 for the Repairs and Improvements of Various Facilities at DSWD Central Office (ITB No. GOP/21-DSWD-023);**

RECEIVED BY : _____ DATE: _____
(SIGNATURE OVER PRINTED NAME)

DESIGNATION : _____

COMPANY : _____

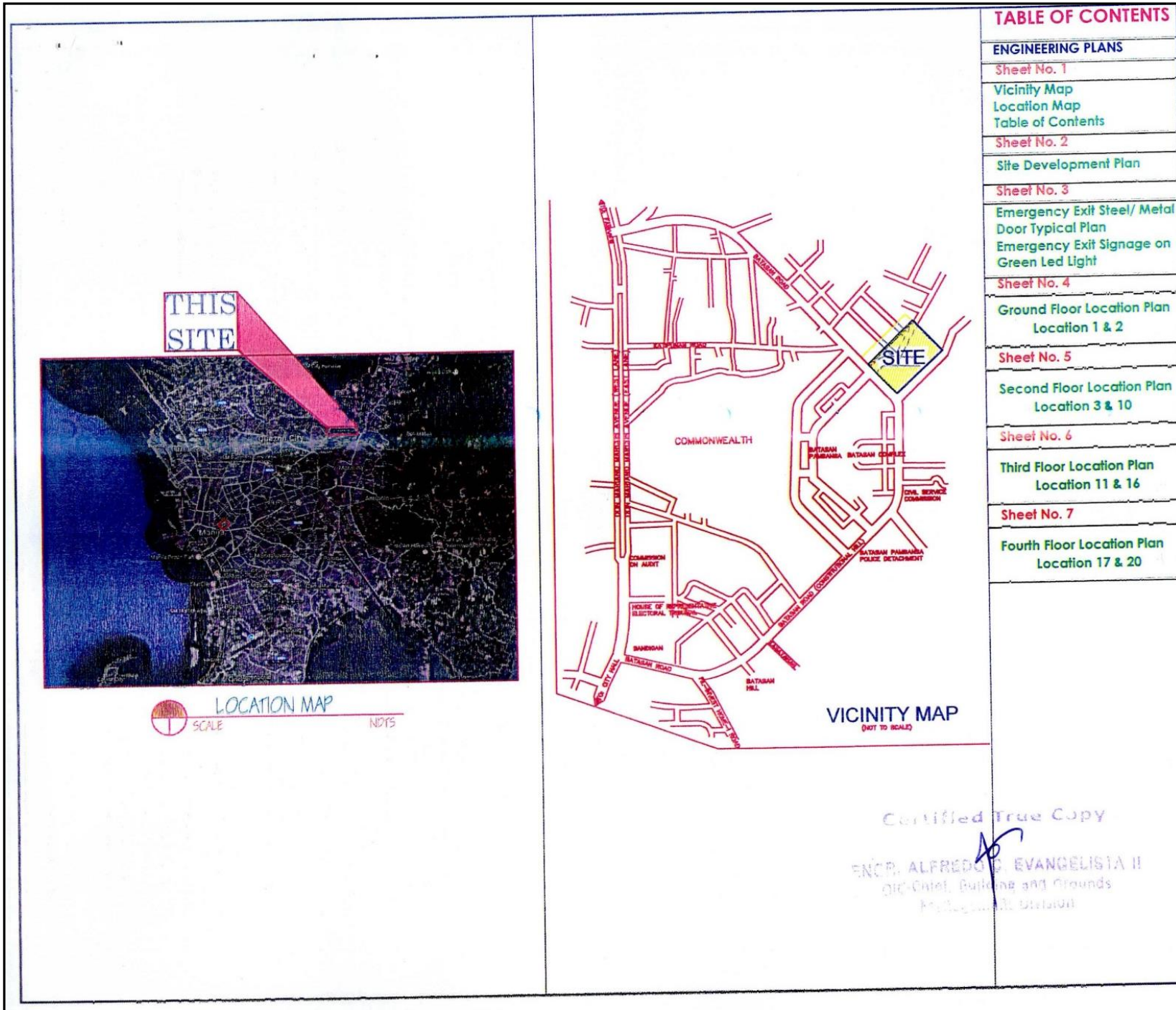

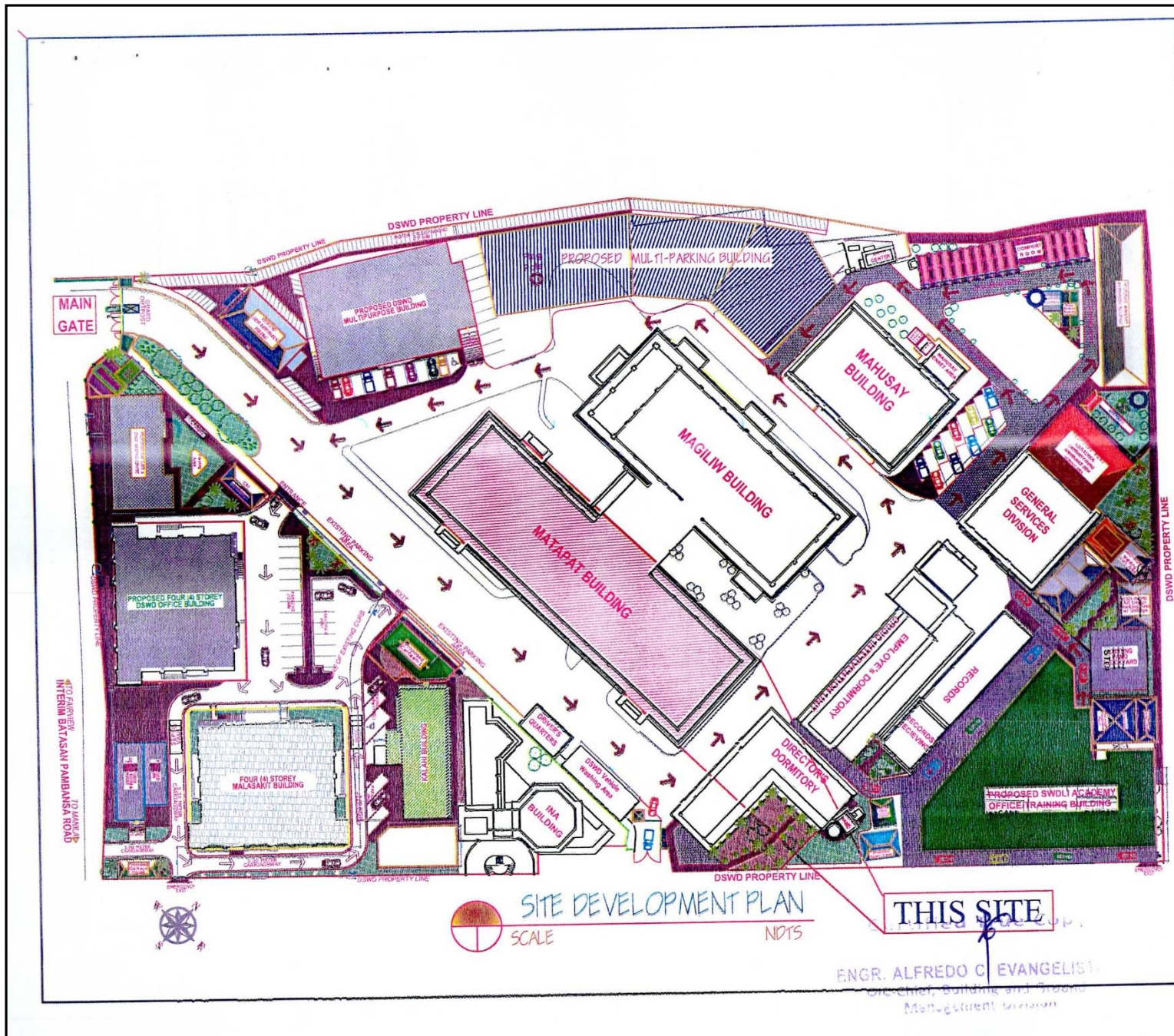

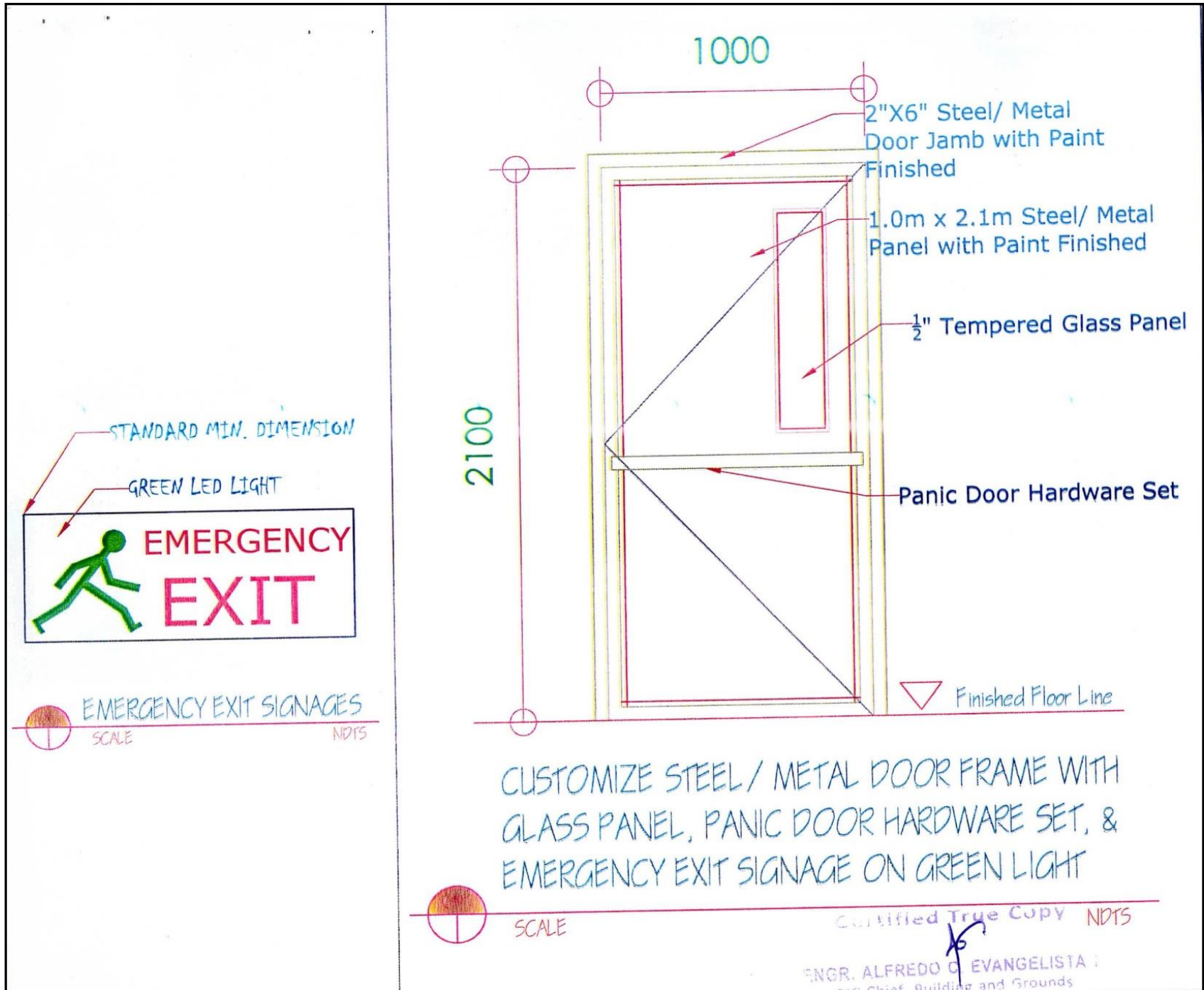

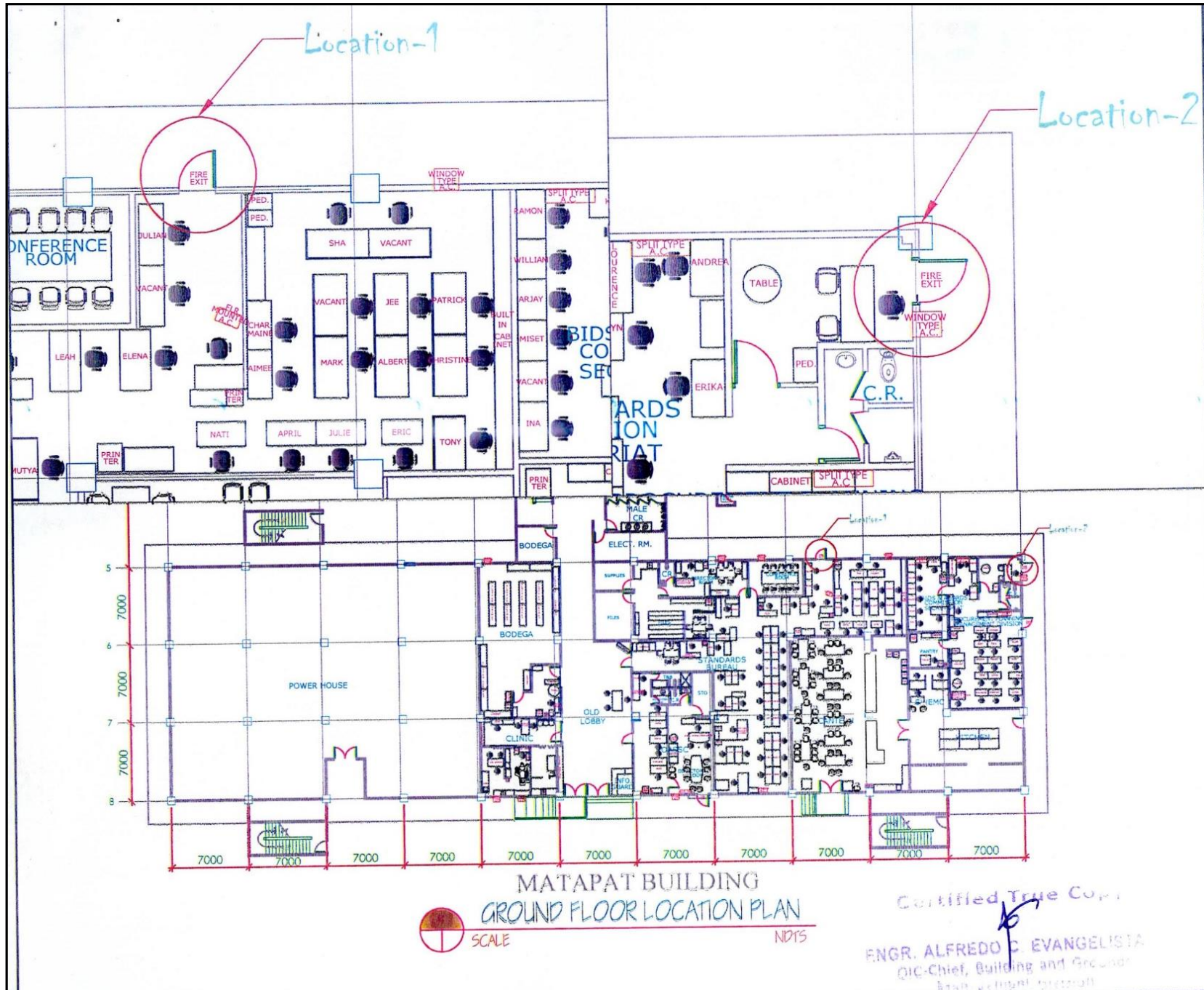

MATAPAT BUILDING
GROUND FLOOR LOCATION PLAN



SCALE

NDTS

Certified True Copy

ENGR. ALFREDO C. EVANGELISTA
PIC-Chief, Building and Grounds
Health, Education, and Social Services

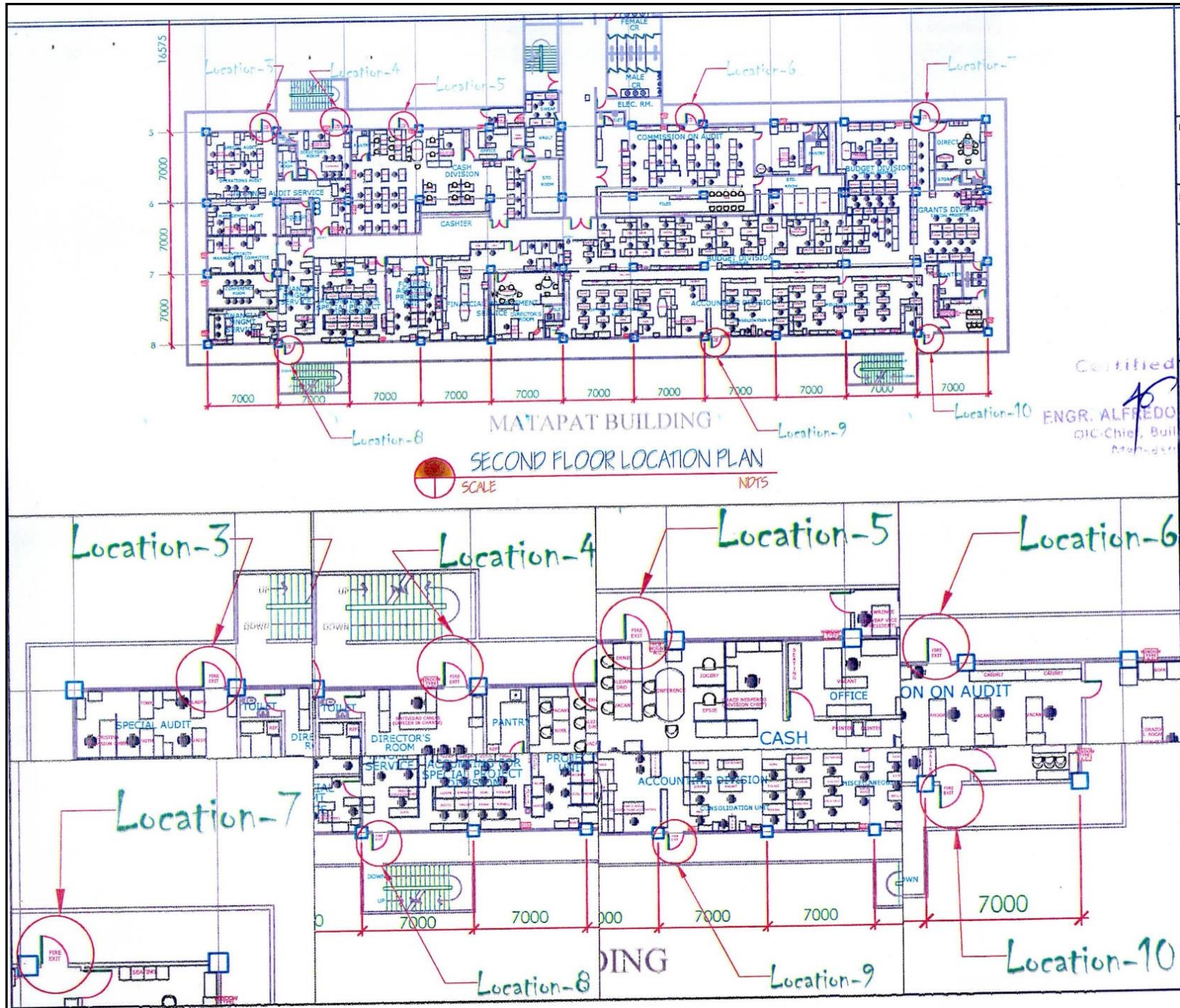

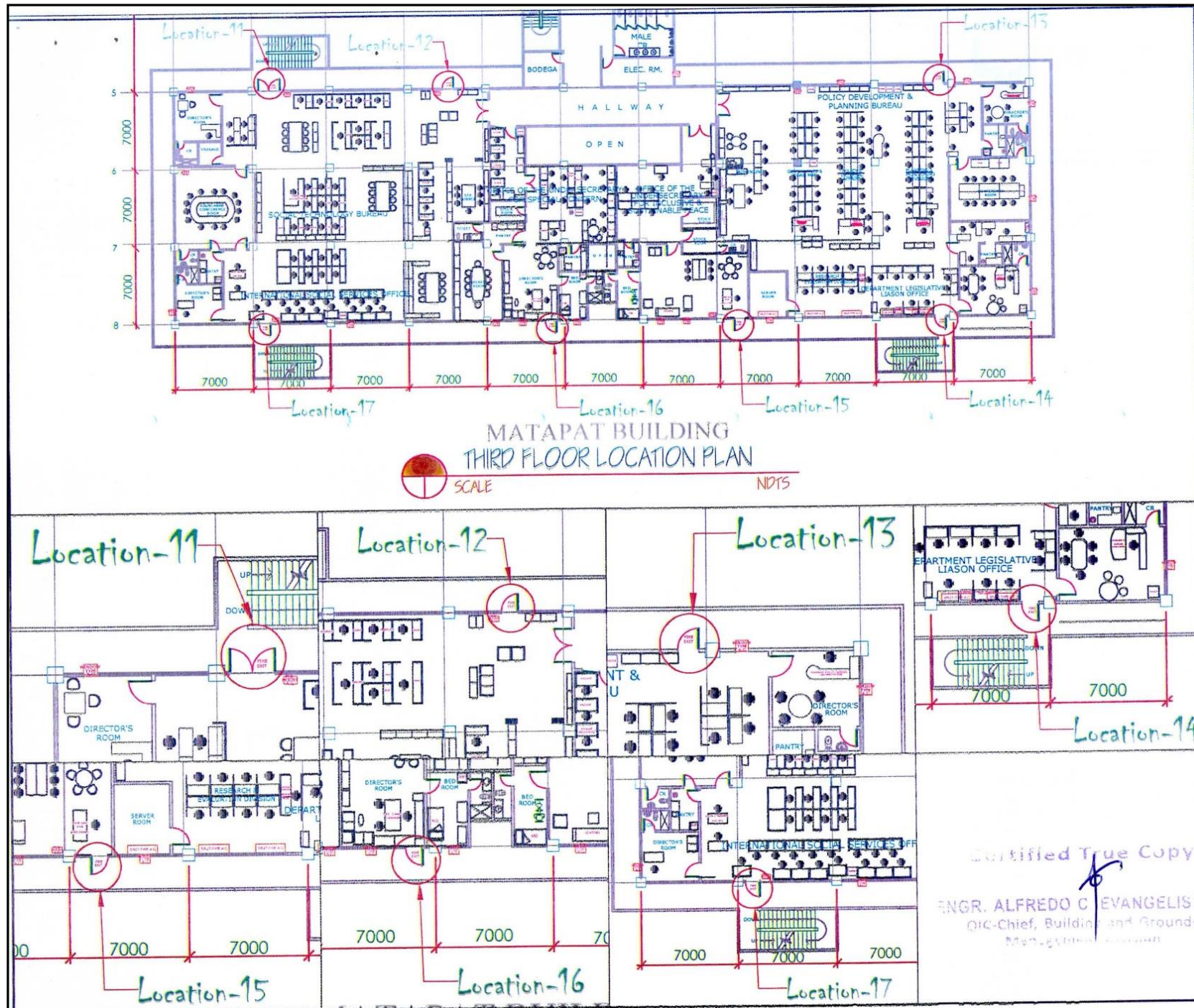

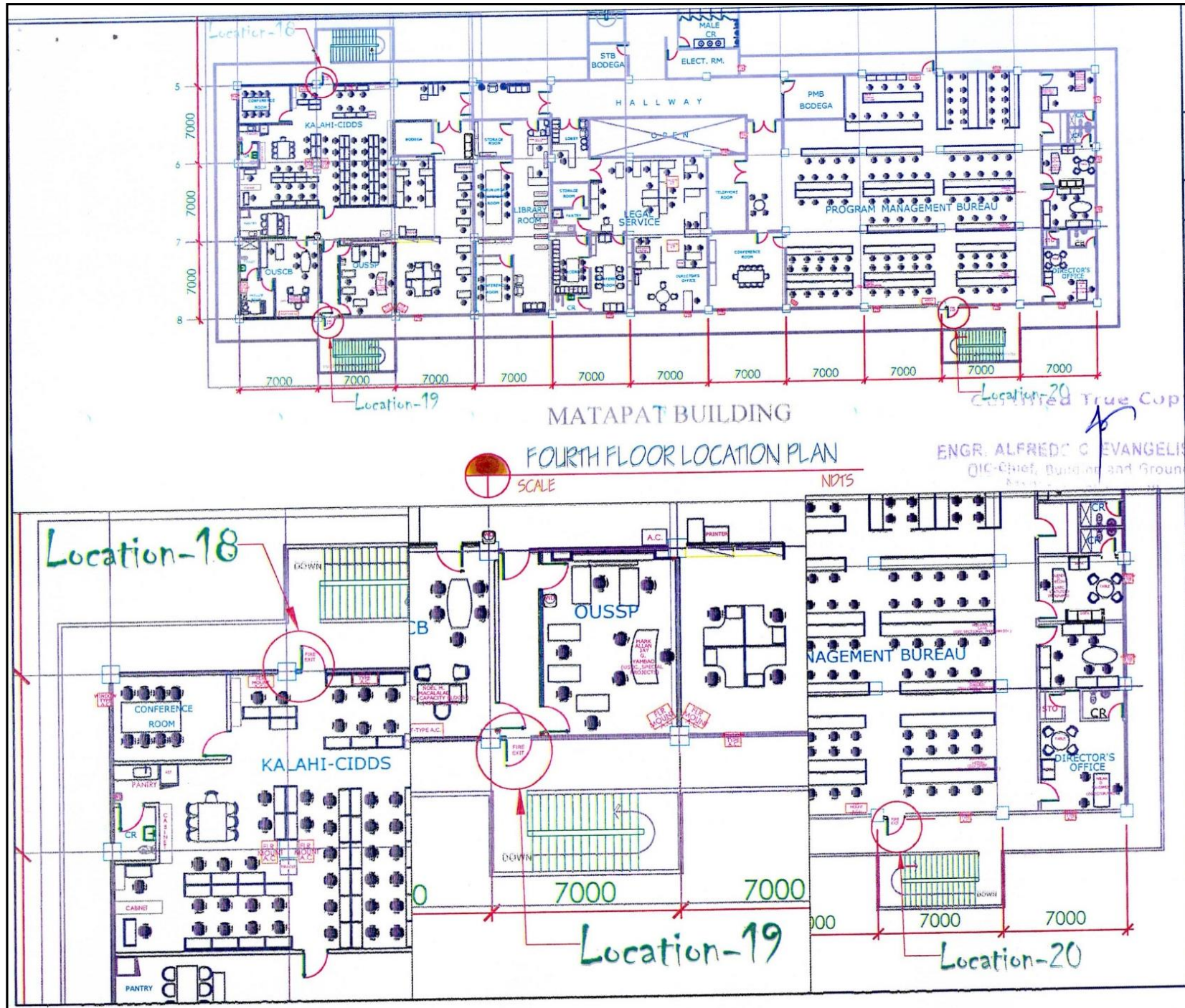

THIS SITE



LOCATION MAP

SCALE

NIPYS

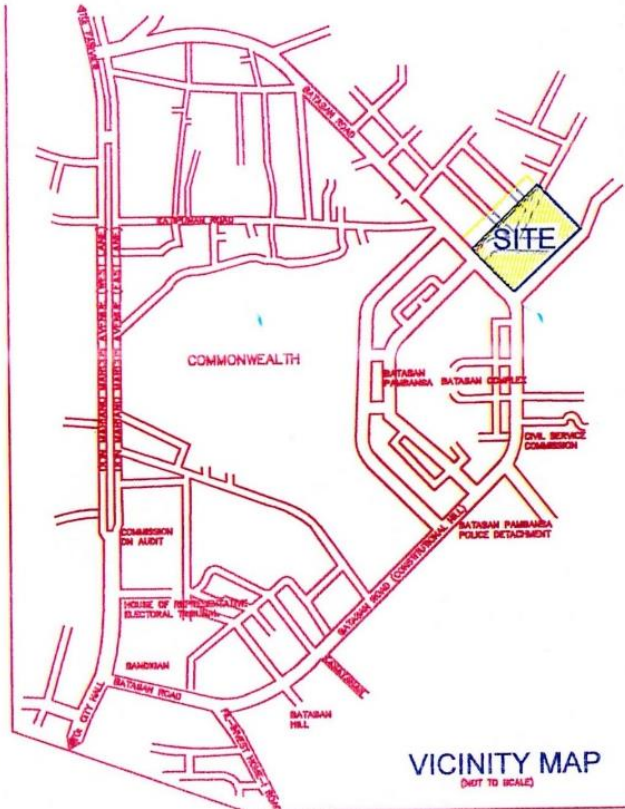

VICINITY MAP
(NOT TO SCALE)

Certified True Copy
As
 NCP. ALFREDO C. EVANGELISTA
 Lic-Chief, Building and Ground
 Management

TABLE OF CONTENTS

ENGINEERING PLANS
Sheet No. 1
Vicinity Map Location Map Table of Contents
Sheet No. 2
Site Development Plan
Sheet No. 3
Overhead Suction Supply Pipe Line Plan
Sheet No. 4
Overhead Concrete Water Supply & Bi-Pass Pipe Line Layout Plan
Sheet No. 5
Overhead Concrete Water Tank Water Motor Pump Electrical Diagram Details
Sheet No. 6
Cistem Concrete Water Tank Detailed Connection for Horizontal Pipes (Under Floor Slab)

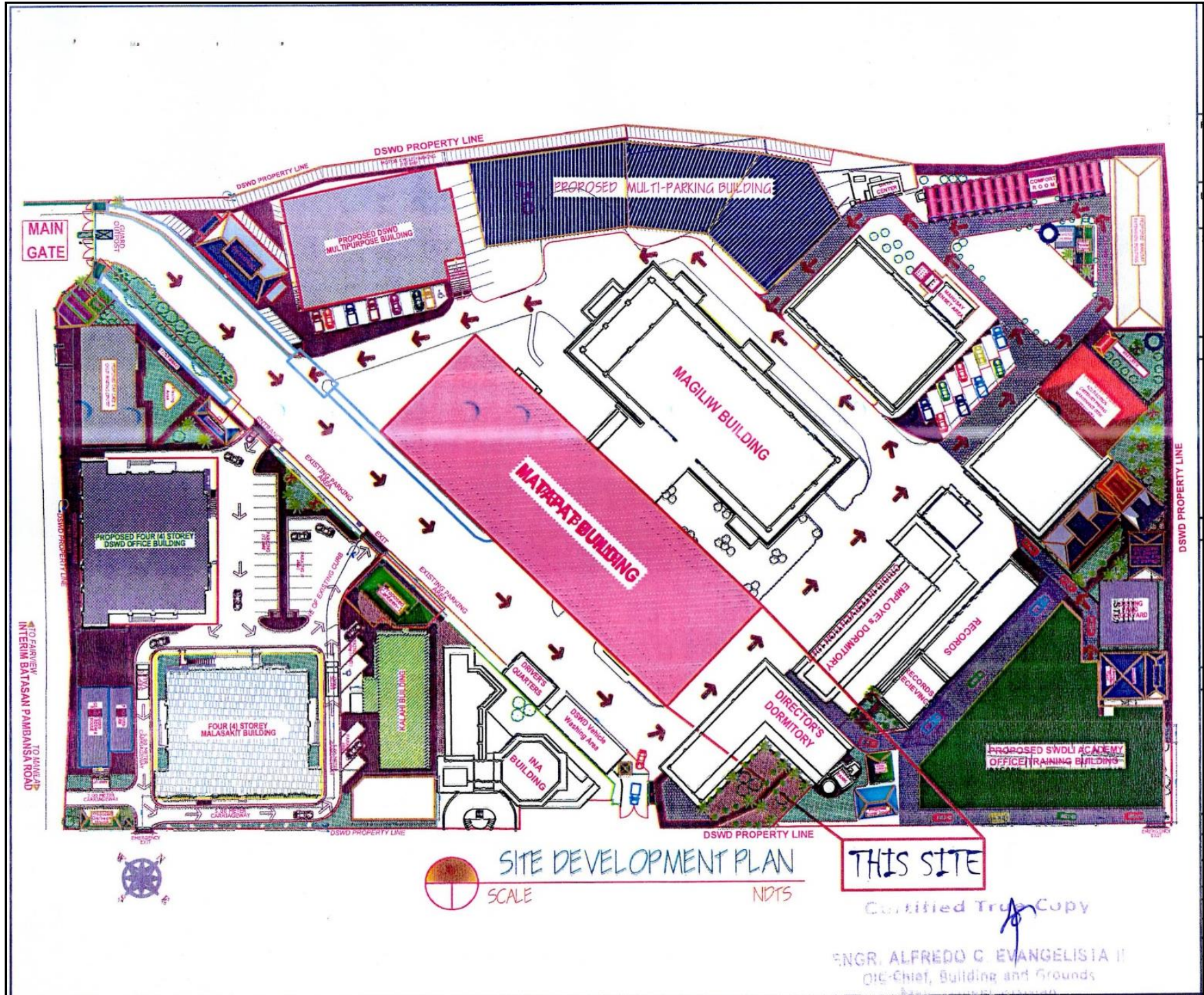

SITE DEVELOPMENT PLAN

SCALE

NDTS

THIS SITE

Certified True Copy

ENGR. ALFREDO C. EVANGELISTA II
 OIC-Chief, Building and Grounds

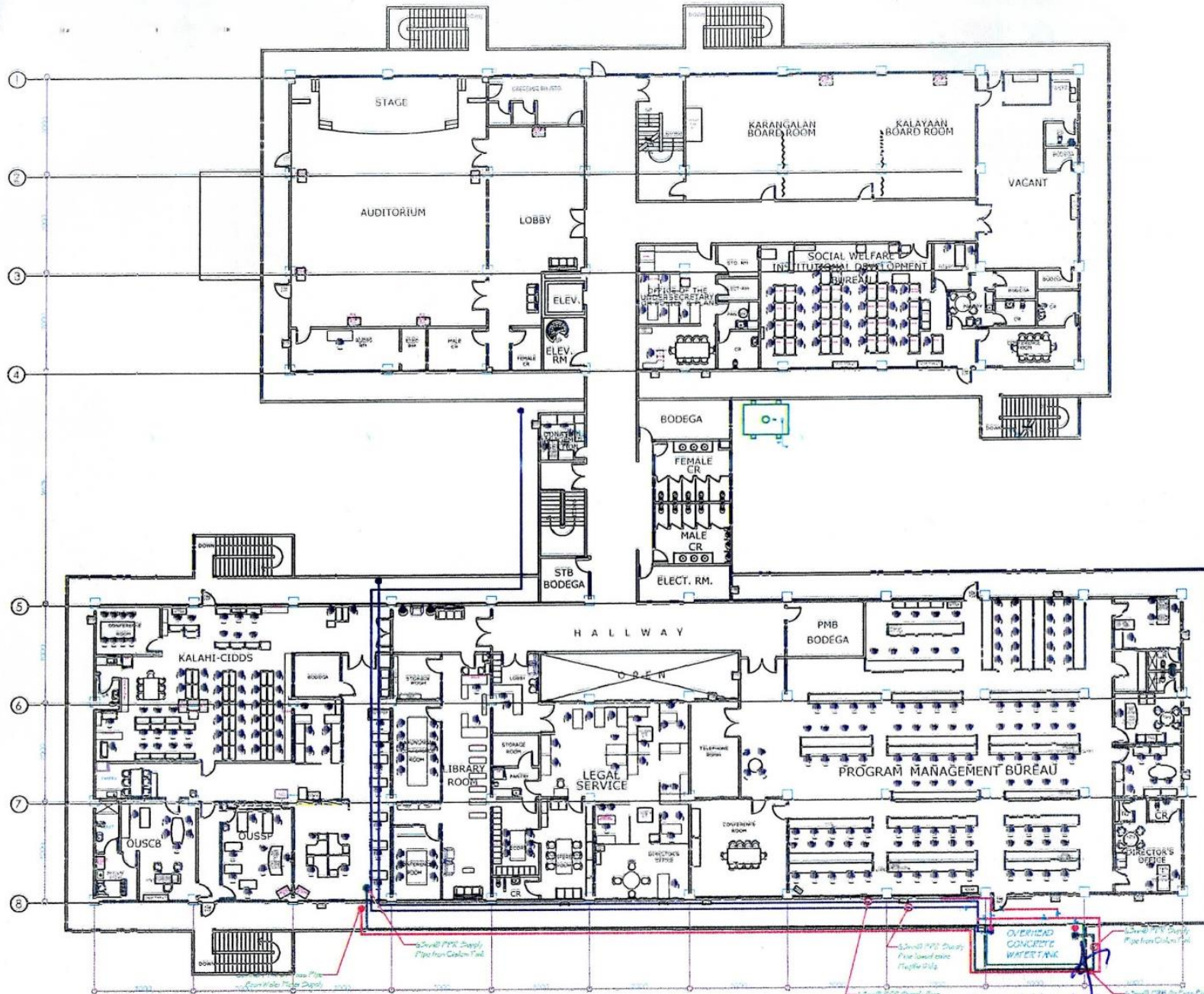

OVERHEAD SUCTION SUPPLY PIPE LINE PLAN
 SCALE NDTs

Certified Trusscopy

ENGR. ALFREDO C. EVANGELISTA II
 OIC-Chief, Building and Grounds

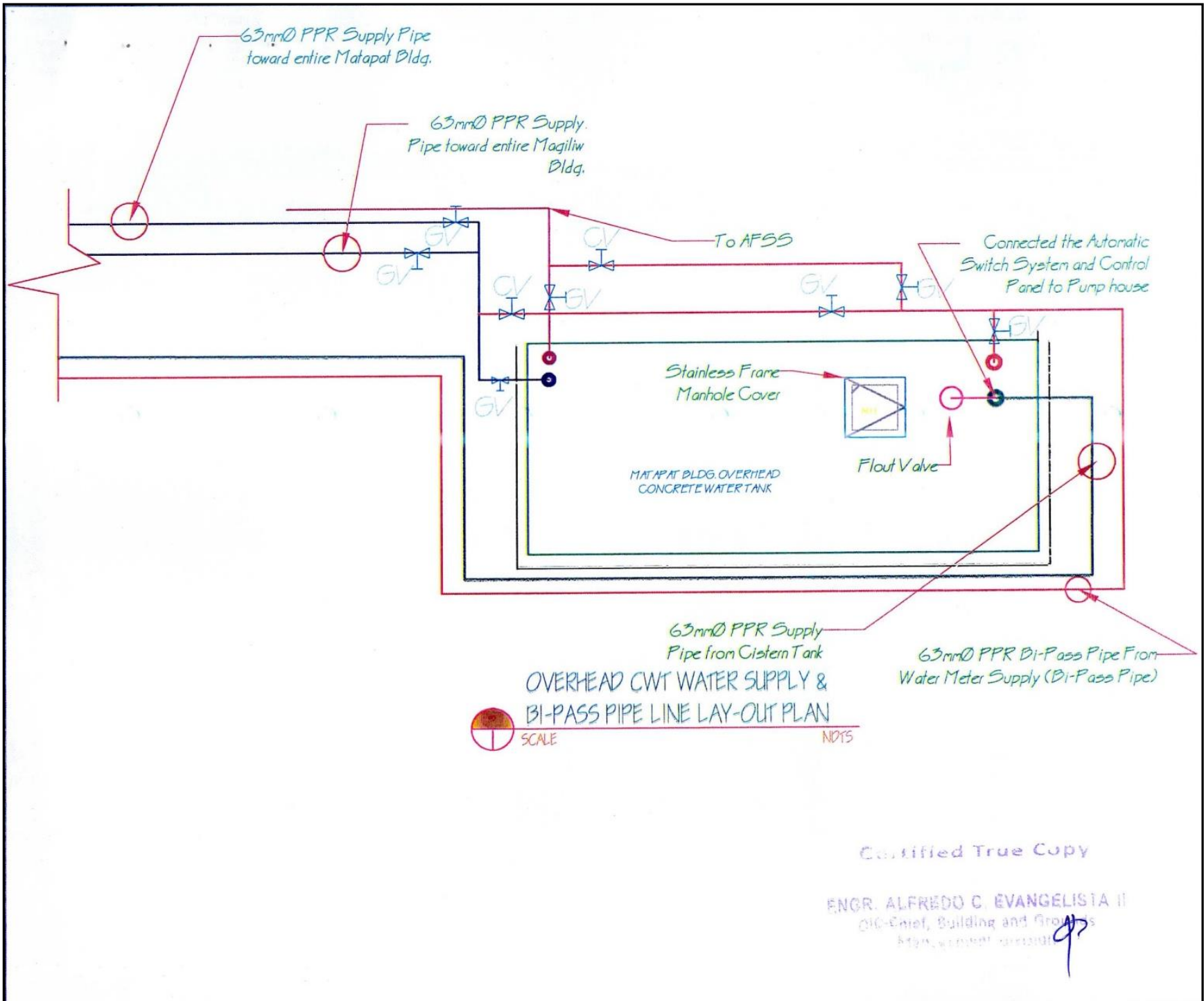

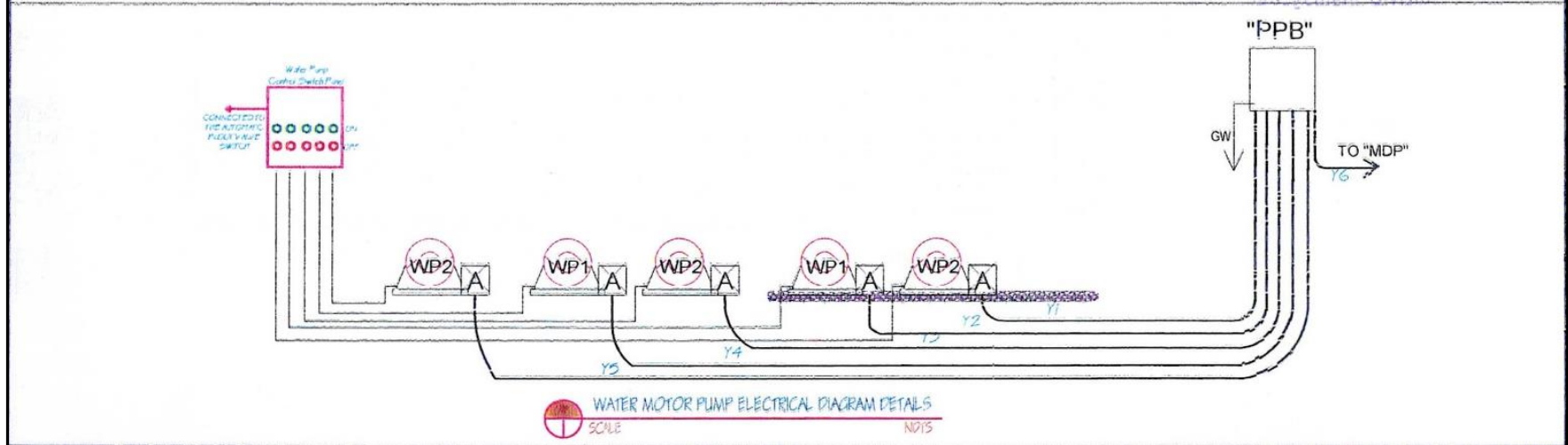
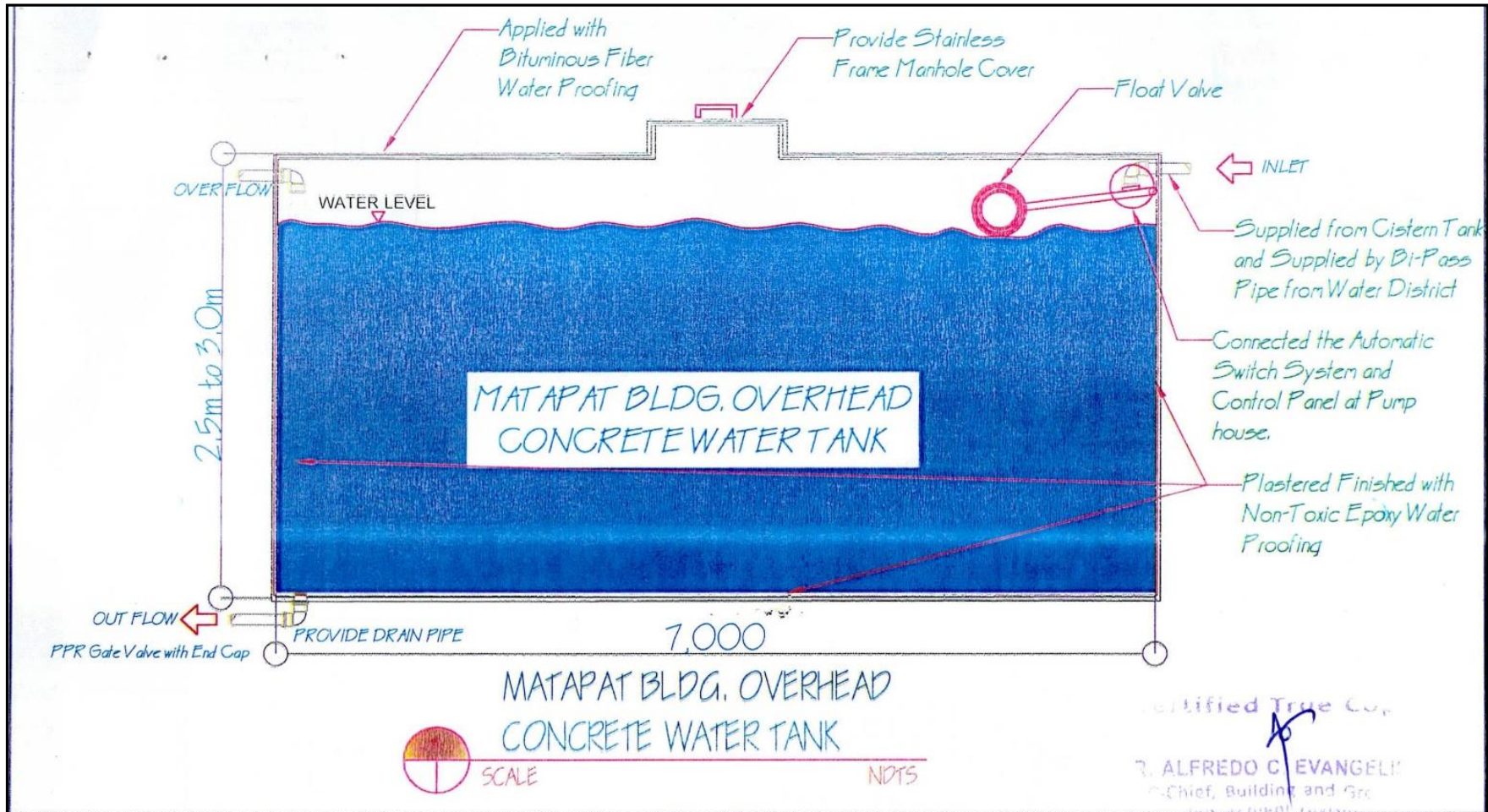

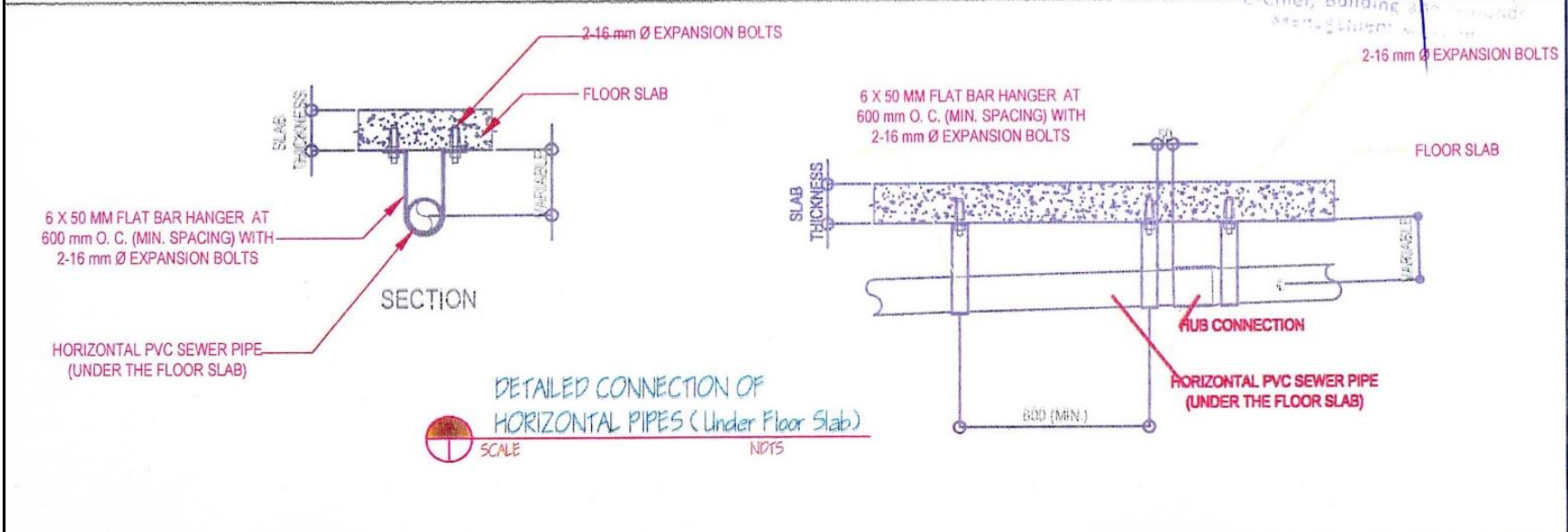
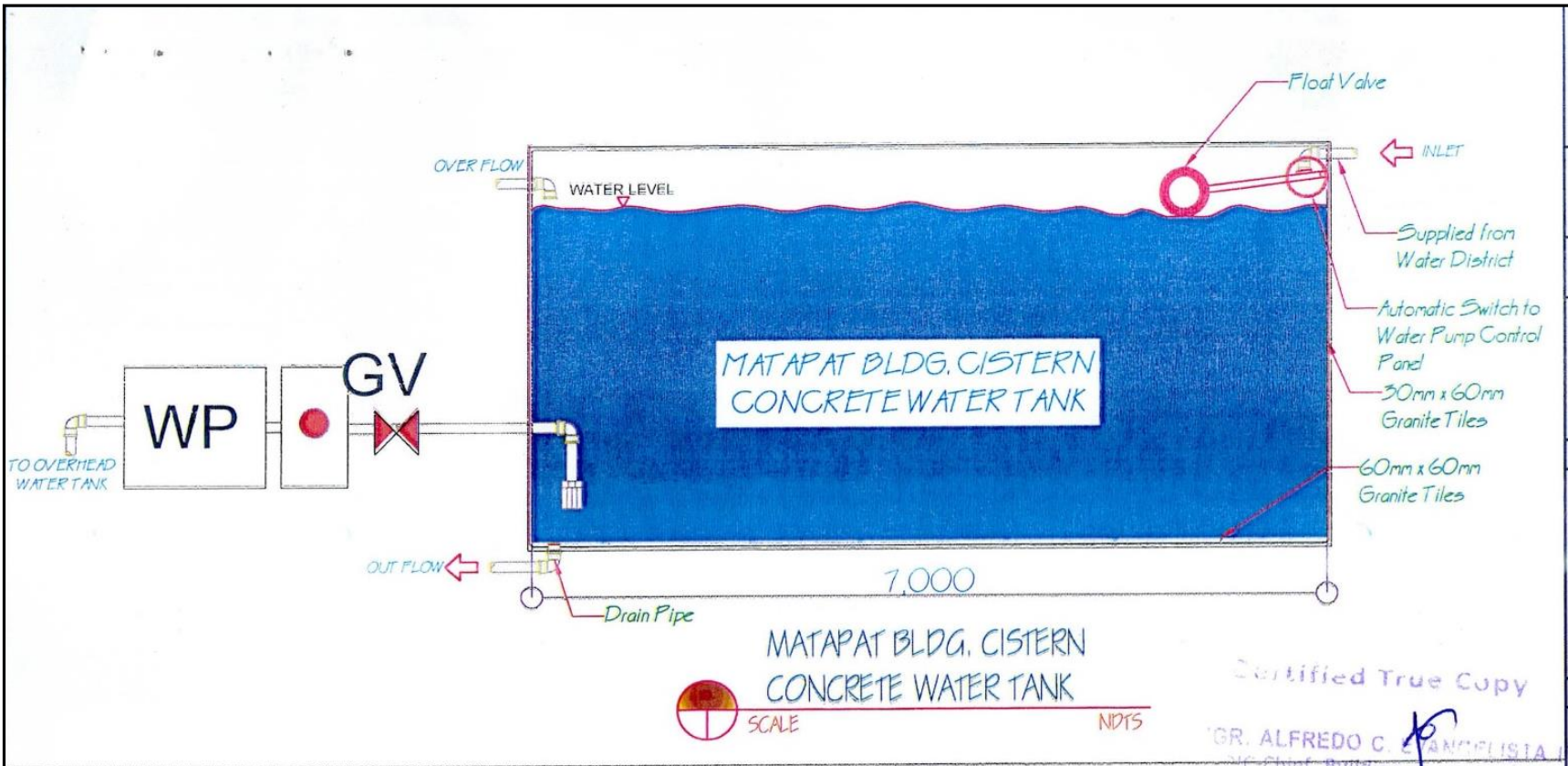



LOCATION MAP
SCALE NOTS

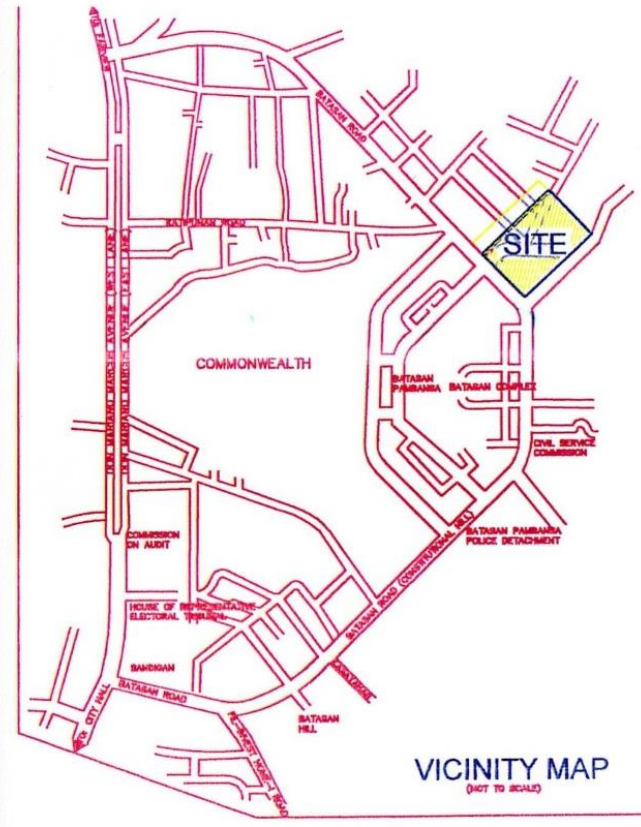

VICINITY MAP
(NOT TO SCALE)

TABLE OF CONTENTS

ENGINEERING PLANS
Sheet No. 1
Vicinity Map
Location Map
Table of Contents
Sheet No. 2
Site Development Plan
Sheet No. 3
Roof Soffit Water Supply Pipe Line Plan
Sheet No. 4
Fourth Floor Water Supply Pipe Line Plan
Sheet No. 5
Third Floor Water Supply Pipe Line Plan
Sheet No. 6
Second Floor Water Supply Pipe Line Plan
Sheet No. 7
Ground Floor Water Supply Pipe Line Plan
Sheet No. 8

Water Supply Pipe Line Plan for Common Comfort Room

Certified True Copy
 ENGR. ALFREDO C. EVANGELISTA II
 OIC-Chief, Building and Grounds

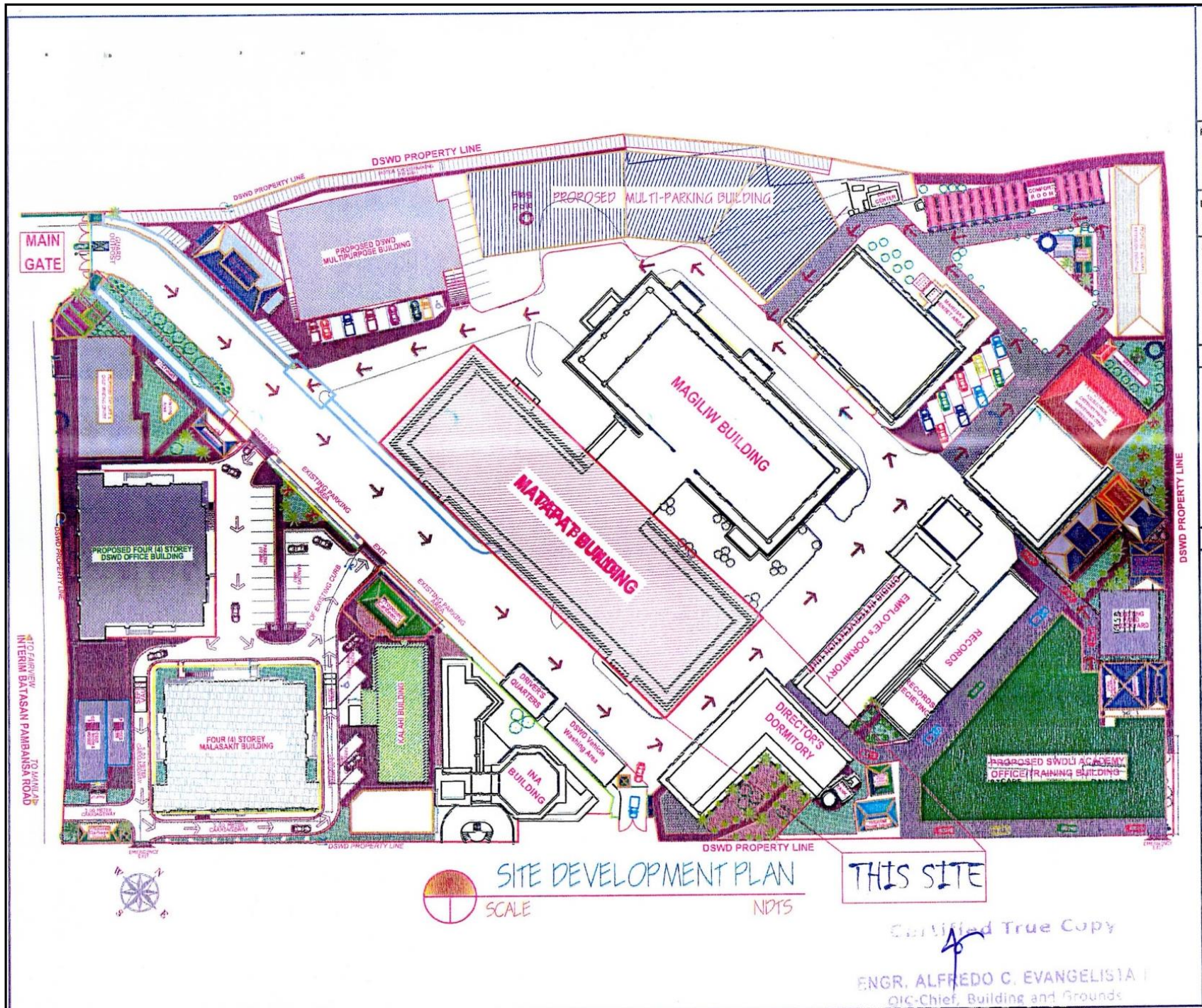

SITE DEVELOPMENT PLAN

SCALE

NDTS

THIS SITE

Certified True Copy

ENGR. ALFREDO C. EVANGELISTA
 PIC-Chief, Building and Grounds

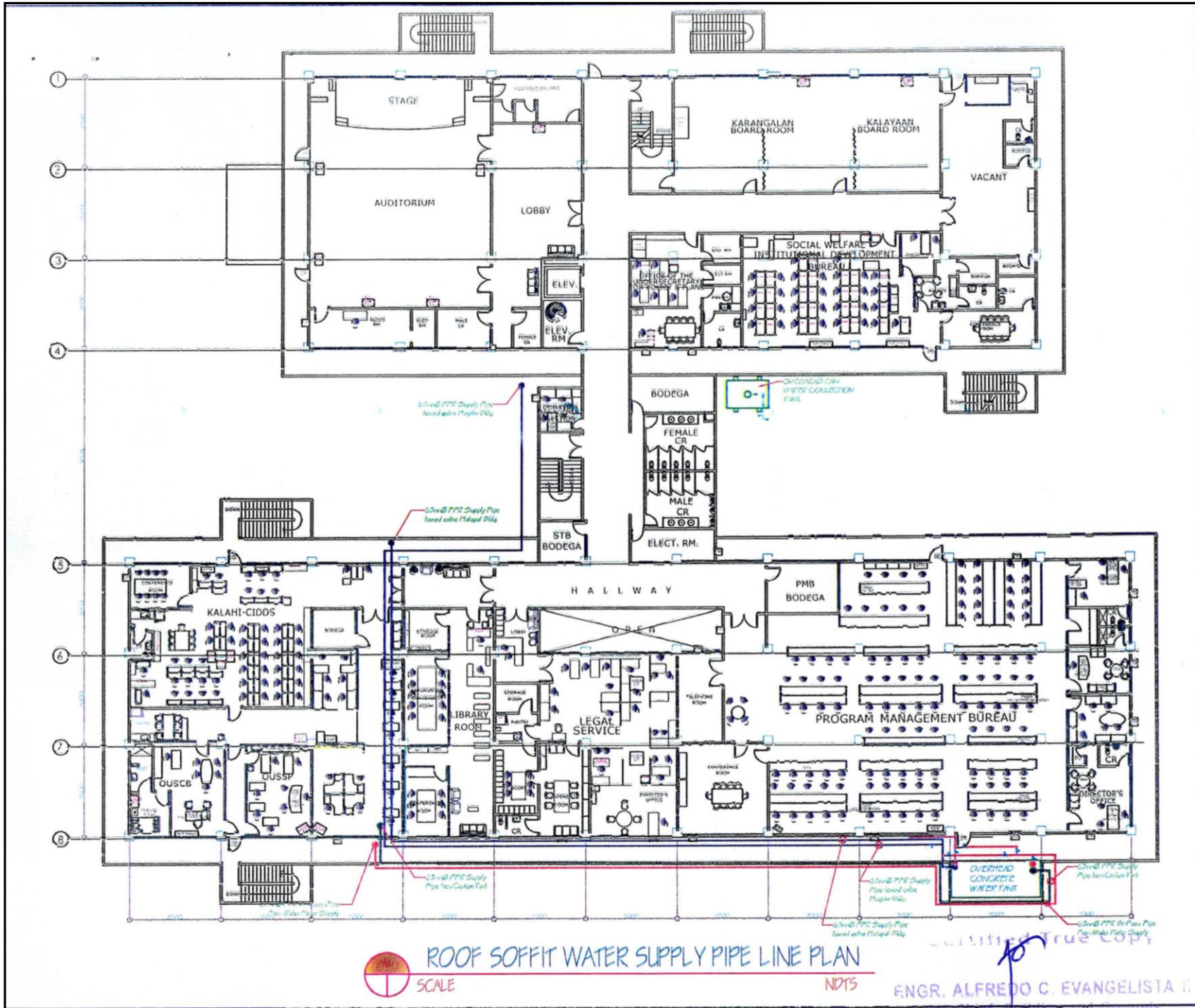

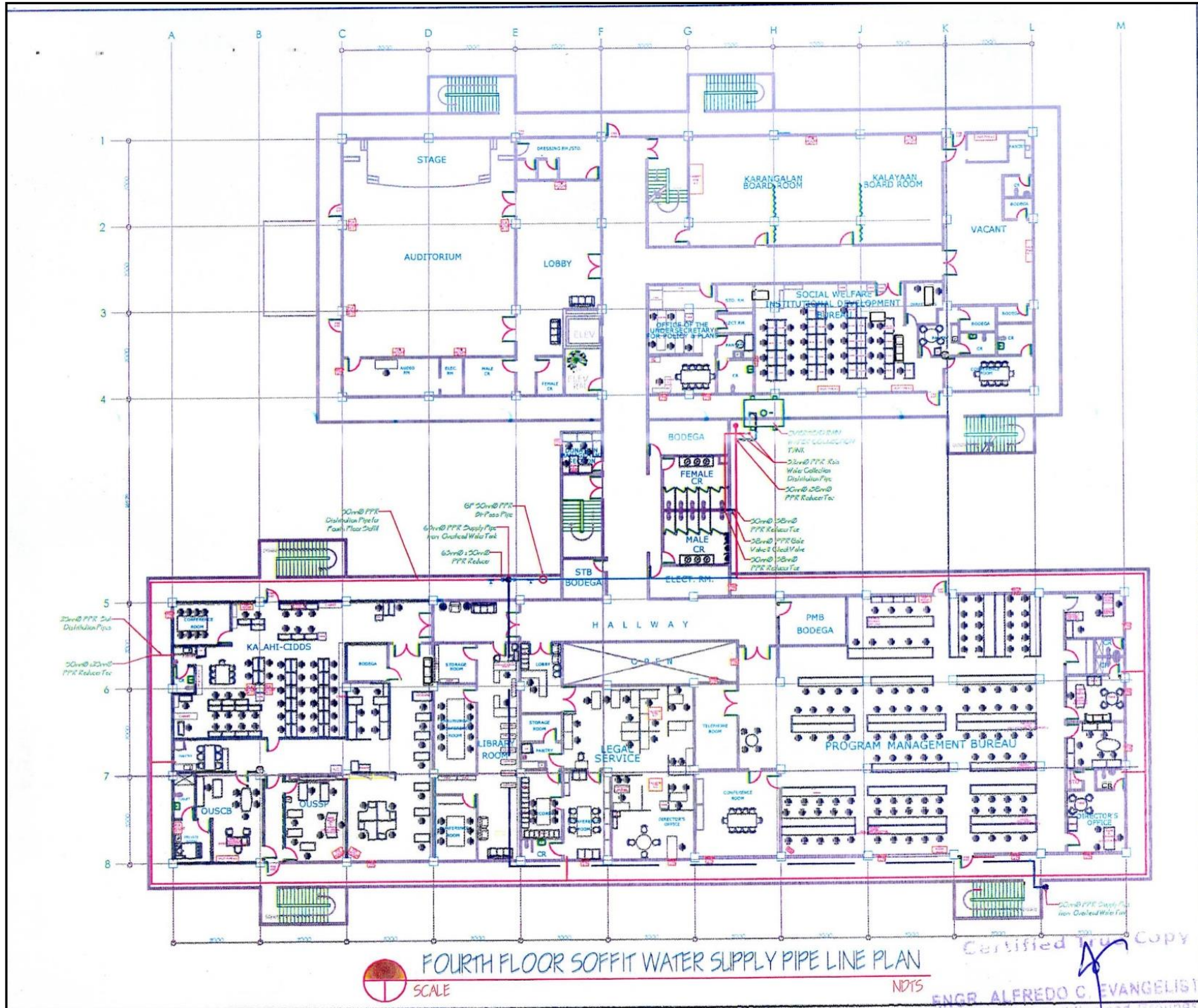

FOURTH FLOOR SOFFIT WATER SUPPLY PIPE LINE PLAN

NDTS

Certified Copy
ENGR. ALFREDO C. EVANGELISTI

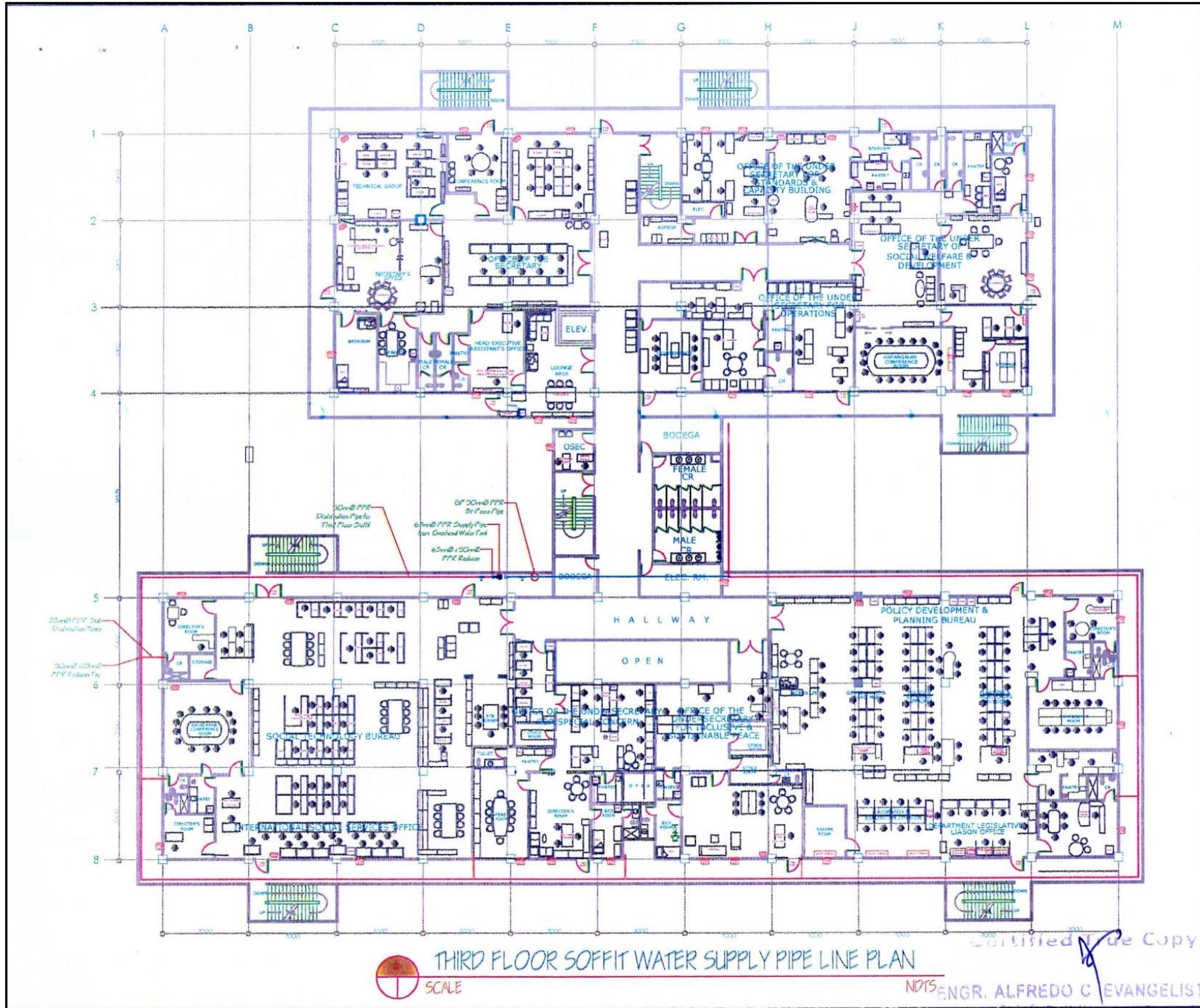

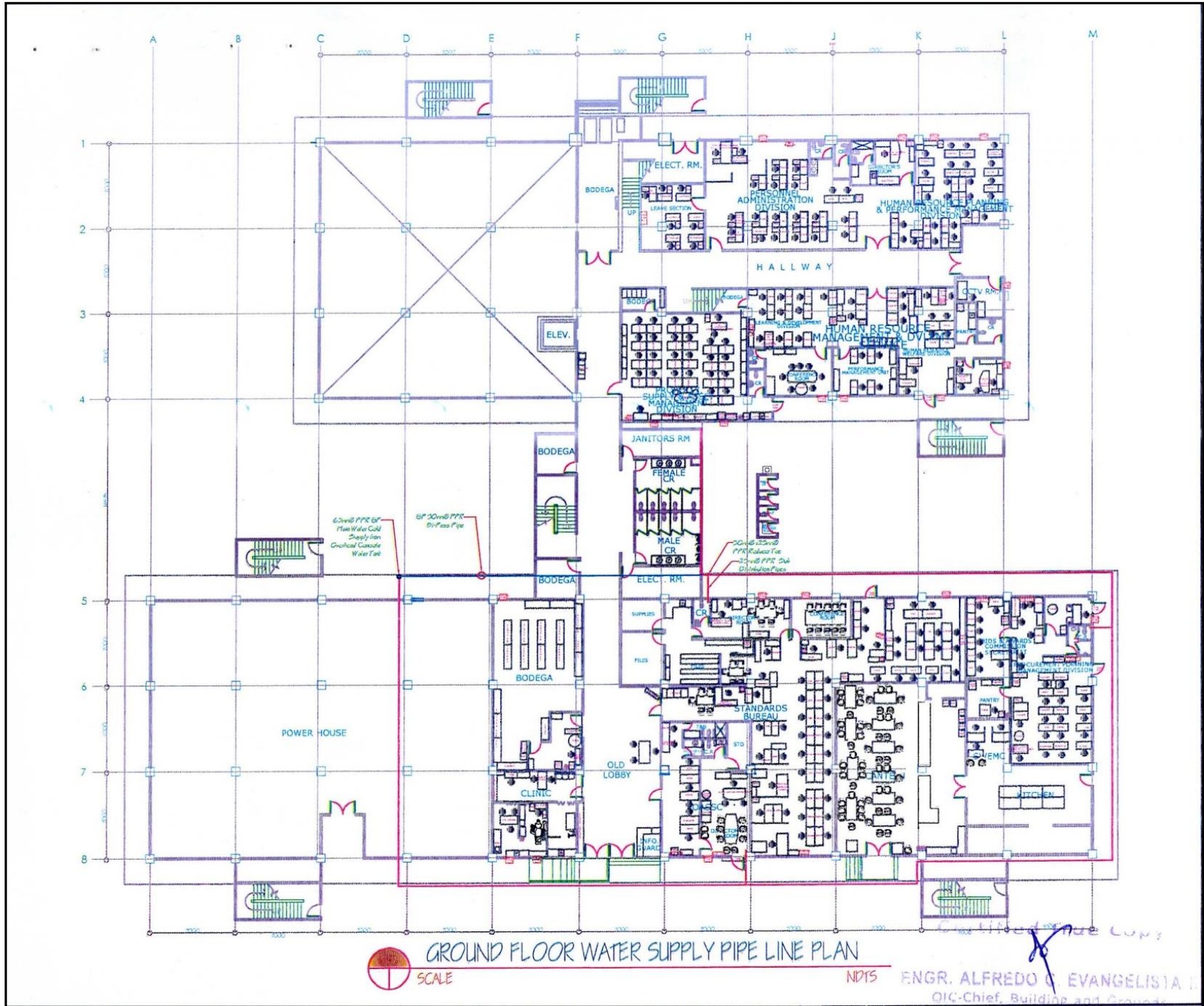

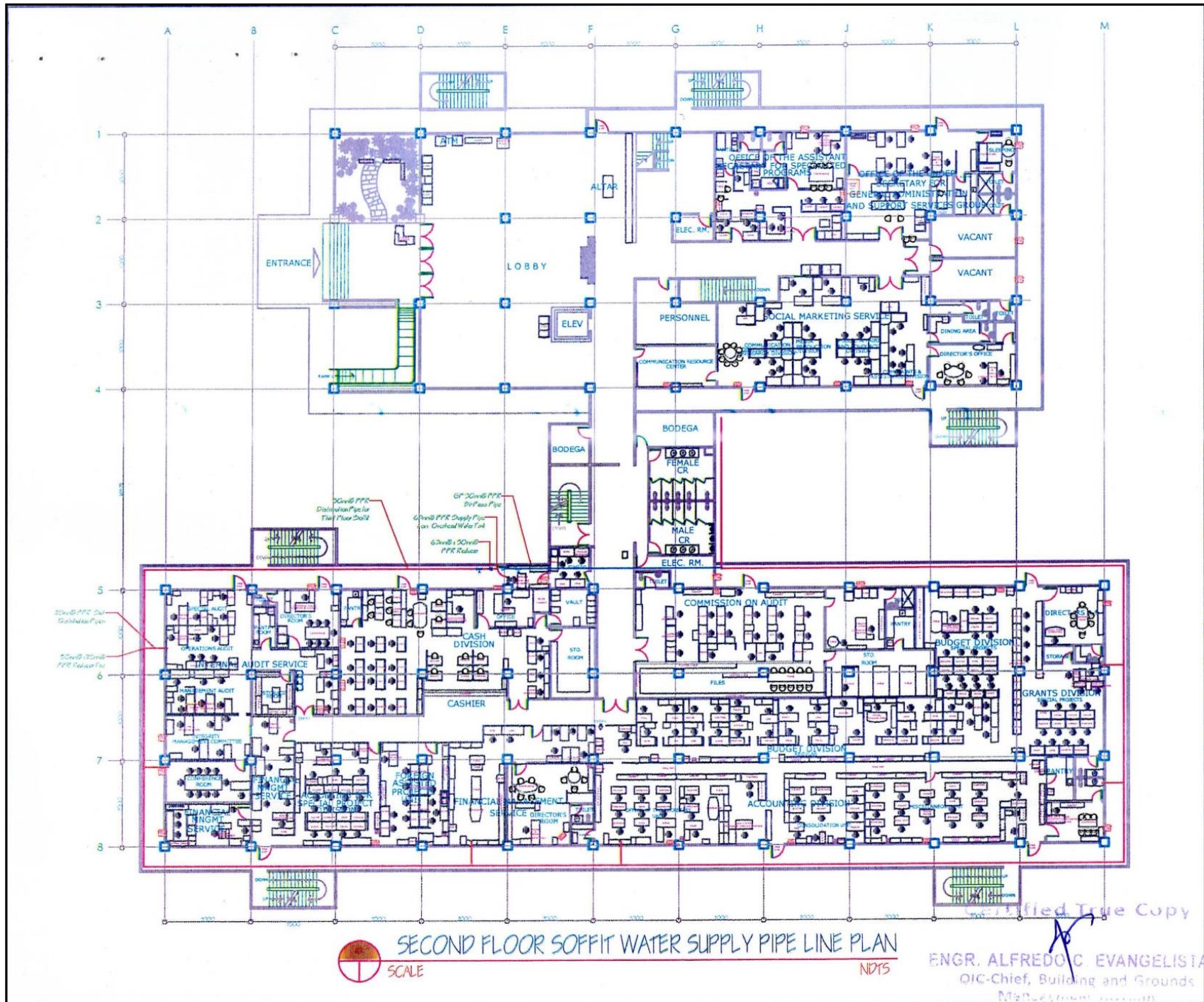

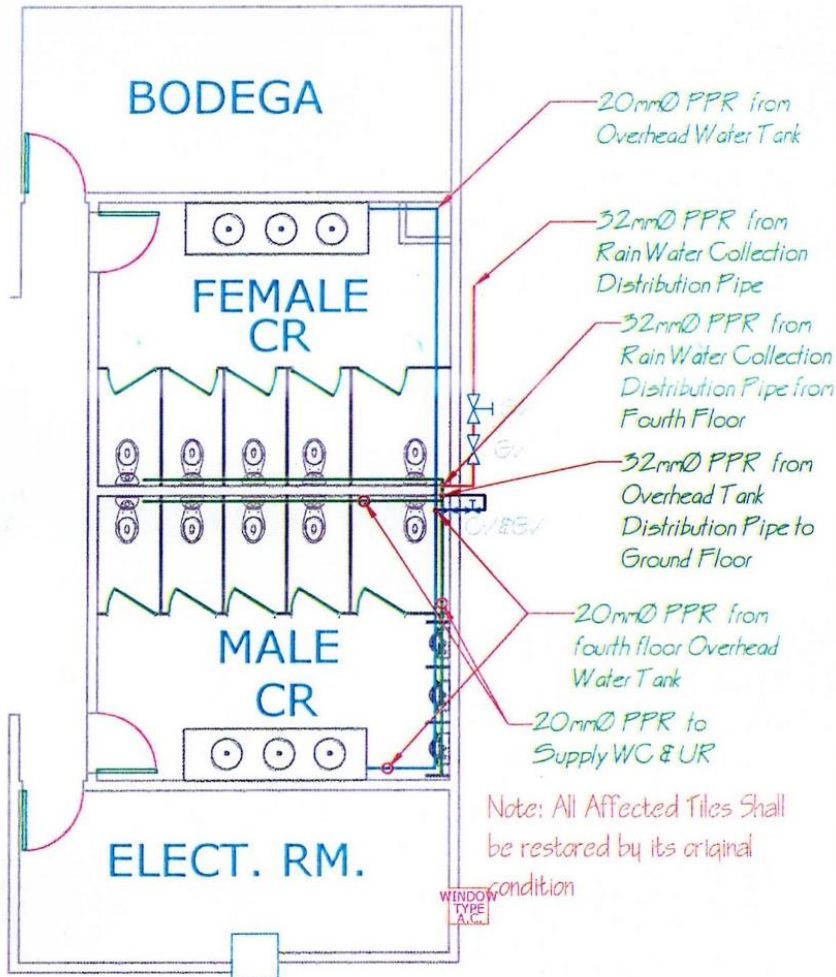

GROUND FLOOR WATER SUPPLY PIPELINE PLAN FOR COMMON CR



NDTS

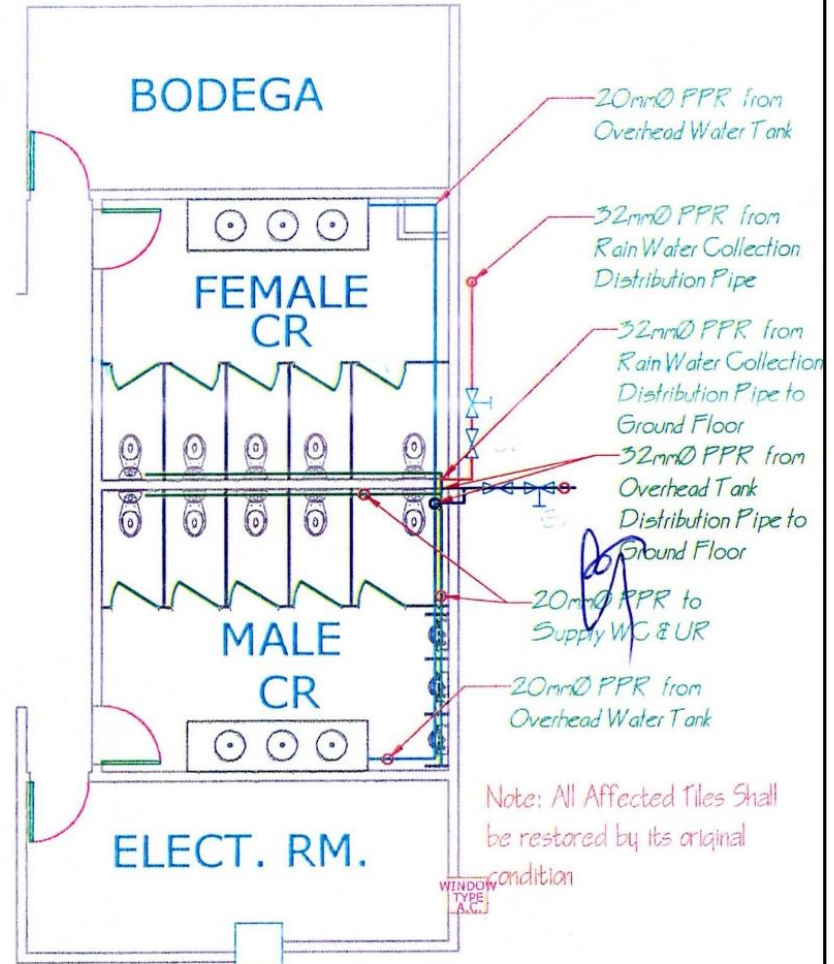

4TH FLOOR WATER SUPPLY PIPELINE PLAN FOR COMMON CR



Certified True Copy NDTS

ENGR. ALFREDO C. EVANGELISTA